

## simple heat control

The terneo sn thermostat efficiently manages snow melting systems, ensuring safe movement for people and vehicles during winter without the need for snow removal equipment or salt.

The temperature is monitored at the location of the temperature sensor. Based on the sensor's data, the thermostat activates heating when the air temperature falls within the specified range.

## IN THE BOX

Thermostat	1 piece
Temperature sensor with connected wire	1 piece
Technical data sheet and installation and operation manual and warranty card	1 piece
The packing box	1 piece

## TECHNICAL DATA

The limits of regulation	upper: 0...10 °C lower: -20...-1 °C
Rated load current (for category AC-1)	32 A (max 40 A in 10 minutes)
Rated power load (for category AC-1)	7 000 VA
Input voltage	230 V ±10 %
Temperature sensor	NTC thermo-resistor 10 kOhm 25 °C (R10)
Supported sensor types:	analog NTC 4.7, 6.8, 10, 12, 15, 33, 47 kOhm at 25 °C
	digital D18
Length of the sensor cable	4 m
Measured temperature range	-30...+85 °C
The number of switches under the load, at least	100 000 cycles
The number of switches without the load, no less than	1 000 000 cycles
Power consumption	no more than 1,5 kW*h/m
Overall dimensions	53 × 85 × 66 mm
Weight in the complete set	0,285 kg ±10 %
Protection degree according to GOST 14254	IP20

## INSTALLATION

The thermostat is mounted and connected after the installation and load testing. **Please read this document in its entirety before installing** and using the temperature controller. This helps to avoid possible hazards, errors and misunderstandings.

If thermostat is installed in a humid room, it should be placed in enclosure with a protection degree not lower than IP55 in accordance with GOST 14254.

The ambient temperature during installation must be between -5 ...+ 45 °C. The installation height of the thermostat should be in the range 0,5...1,7 m above the floor level.

The temperature controller should be mounted in a special cabinet, which allows accessible installation and operation. The cabinet must be equipped with a standard 35 mm mounting rail (DIN-rail). The temperature controller has width of three standard 18 mm modules.

The thermostat is mounted and connected after the installation and load testing.

In order to protect from short circuits and excess power events appearance in the load circuit, it is necessary to install an automatic circuit breaker (CB), which should be installed in the live wire break, as shown on Wiring 1.

In order to protect a person from electric shock, a residual current device (RCD) should be installed. The load should be grounded (connected to the protective conductor) for proper operation of the RCD or, if the power supply is two wire, a protective grounding (i.e. load to neutral to the RCD) should be made.

The terminals of the temperature controller are designed for a wire with a cross section not exceeding 16 mm<sup>2</sup>. It is desirable to use a soft copper wire to reduce the mechanical loads on the terminals. The use of aluminum is not desirable. Strip the ends of wires 10 ± 0,5 mm. If the stripped end is longer, it may cause a short circuit and, if shorter, can cause an unreliable connection. Use cable lugs. Loosen the terminal screws and insert the stripped end of the wire into the terminal.

Tighten the power terminal with moment of 2,4 N·m and sensor terminal — 0,5 N·m. Poor tightening can lead to poor contact and overheating of terminals and wires, and excessive tightening — to damage of terminals and wires. The wires are tightened in the power terminals with a screwdriver with a bit width of not more than 6 mm, and in the terminals for the sensor — of not more than 3 mm. A screwdriver with a bit width of more than 6 mm for power terminals (more than 3 mm for sensor terminals) can cause mechanical damage to the terminals. This may cause to the loss of the warranty.

It is necessary for the temperature controller to switch the current to no more than 2/3 of the maximum current specified in the specification. If the current exceeds this value, the load must be connected through a contactor (magnetic actuator, power relay), which is optimized for this current (Wiring 2).

### Air temperature sensor installation

Air temperature sensor should be mounted on the wall or under the edge of the roof in order to ensure its protection from direct sunlight, rain and snow, and ensure

the opportunity for easy replacement in the event of a malfunction or damage (Fig. 1). If necessary, it is allowed to shorten and expand sensor connecting wires (separate cable not more than 20 m long with a cross-section greater than 0,75 mm<sup>2</sup>). Power wires should not be placed near connection wire of sensor otherwise they may cause interference.

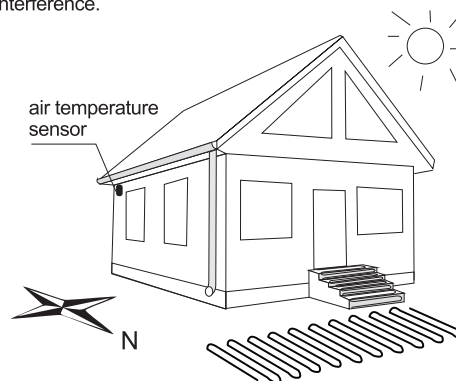

Figure 1. Air temperature sensor installation

## WIRING

The thermostat supports two types of sensors: analog (R10) and digital (D18). The analog sensor is supplied with the thermostat and is connected to terminals 1 and 2.

To connect a digital sensor, connect the blue wire to terminal 2 and the white wire to terminal 1, and be sure to change the Sensor type to d18 in the menu.

The supply voltage (230 V ±10 %, 50 Hz) is supplied to terminals 3 and 4, and the phase (L) is determined by the indicator and is connected to terminal 4, and a neutral (N) — to the terminal 3.

The load wires are connected to terminal 5 and a neutral terminal block (not included in the set).

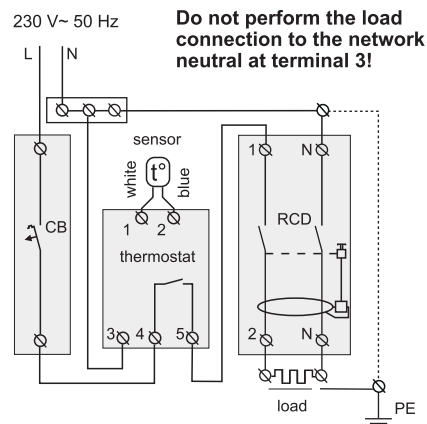

Wiring 1. Connection diagram of the thermostat, circuit breaker and RCD

230 V ~ 50 Hz

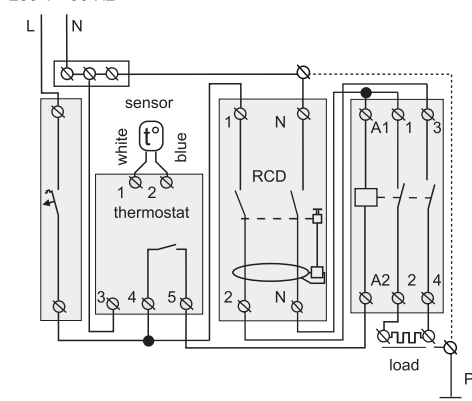

Wiring 2. Connection through a contactor (magnetic starter)

## WARRANTY TERMS

The warranty for devices is valid for 36 months from the date of sale, provided that the instructions are followed. The warranty period for products without a warranty certificate is counted from the date of production.

If your device is not working properly, we recommend that you first read the section "Possible problems". If you cannot find an answer, contact Service Center, in most cases, these actions resolve all issues.

If you continue to have issues with the device, please, contact the General distributor in your area or the store where you purchased the device. If your device is defective due to our fault, we will repair or replace it under warranty within 14 business days.

Please check the full text of the warranty and the data you need to send to your Service Center on the website <https://www.ds-electronics.com>

## WARRANTY CARD

serial №:	date of sale:
a seller, a seal:	place of a seal
an owner contact for a service center:	

## EXPLOITATION

### Switching on thermostat

 To turn on the thermostat, apply voltage to terminals 3 and 4. The display will show "888" for 3 seconds. Then the sensor temperature will be displayed. To turn off the thermostat, switch off the circuit breaker

### Setting temperature limits

(factory setting upper limit 5 °C, lower -15 °C)  
To view the upper temperature threshold, press the "+" or "-" to view lower temperature threshold. Flashing value can be changed by means of "+" or "-" buttons. If sensor temperature is within the specified limits, the heater will turn on and the red indicator will switch on.

### Menu

Use "≡" to navigate the menu, and "+" or "-" to adjust parameters. The first button press makes the parameter blink, while the second press changes its value. If no buttons are pressed for 5 seconds, the display will revert to showing the temperature.

#### Manual heating activation 1 time

It is used to force the heater to switch on, for example, to test the system during commissioning. (factory setting "hoF" — heating off)



To activate Manual Heating, select "hon" and then use the "+" and "-" buttons to set the heating duration within the range of 0.5 to 9 hours in 0.5-hour increments (default: 3 hours). The display will indicate active Manual Heating by alternating between the remaining time until the heater switches off and the "hon" message every 10 seconds.

#### Load operating time counter 2 times

Press "+" or "-" to view, the next "-" press resets the counter.



Allows you to calculate the energy consumption since the last reset of the meter by multiplying the operating time by the load power and the tariff. Displays the time using a ticker (hours and minutes).

#### Correction on the screen 3 times

(factory setting 0, range ±5 °C)



If necessary, use the temperature correction on the thermostat screen. Step 0,1 °C

#### Hysteresis 4 times

(factory setting "1.0", range 0,1..10 °C, step — 0,1 °C)

Hysteresis — his is the difference between the temperature of the load turn on and off.

Illustration of heater operation with factory settings: temperature range 5...-15 °C, hysteresis 1 °C is shown in Fig. 2.

If the selected hysteresis value exceeds the set range, the thermostat will recalculate the hysteresis. For example, with a hysteresis of 3 °C and a range of -1...0 °C, the hysteresis will be recalculated as 1/2 = -0.5 °C. An illustration of thermostat operation in such a case is shown in Fig. 3.

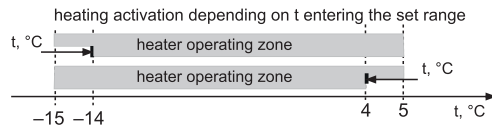

Figure 2. Standard limits with 1 °C hysteresis.

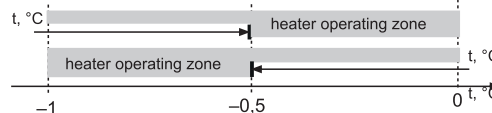

Figure 3. Minimum limits with hysteresis > 1 °C.

#### Sensor type 5 times

(factory setting 10r)



Select the type of sensor you are using: analog sensor — 4.7r, 6.8r, 10r, 12r, 15r, 33r, 47r, where r — is kΩ at 25 °C, digital sensor — d18.

#### Switching on / off the load

(factory setting "on")



To turn off the load, press and hold the "≡" button for 4 sec: the screen will sequentially display 3 dashes, followed by "oFF". To turn it back on, press and hold "≡" for 4 sec again.

### Reset to factory settings

 Hold the 3 buttons for 12 seconds until "dEF" appears. When released, the thermo-stat will reset and reboot.

### Firmware version

Hold "-" button for 6 seconds. The manufacturer reserves the right to make changes to the firmware in order to improve the characteristics of the thermostat.

### Technical Support Chat

 If you haven't found the answer, please contact our technical support engineer

 [dselectronics\\_bot](#)  
 [terneo\\_official](#)

## POSSIBLE PROBLEMS, CAUSES AND WAYS TO OVERCOME THEM

### The load does not work, the screen says "oht"

 Temperature inside the frame exceeds 80 °C, triggered protection against internal overheating

*Instructions:* Check the tightness of the power wires in the thermostat terminals; ensure that the power of the connected load does not exceed the permissible limit, and the wire cross-section for connection is selected correctly.

*Features of the internal overheating protection:* when the temperature inside the casing drops below 60 °C, the thermostat will resume operation. If the protection is triggered more than 5 times in a row, the device will be locked until the temperature inside the casing drops below 60 °C, and one of the buttons is pressed.

### Every 4 sec the screen displays "Ert"

 *Reason:* open or short circuit of the internal overheating sensor. Control over inner overheating will not be done.

*Required:* Send the device to the Service Center.

Otherwise, control over inner overheating will not be done.

### The load is disabled, indicator nor the screen light up

*Possible reason:* no power supply voltage.

*Required:* check availability of power supply voltage. If power supply voltage is available then contact the Service.

### Load does not work according to settings, every 5 seconds screen displays "OS" or "SC"

 The thermostat has entered the Emergency Timed Mode (described below). The screen continuously displays "oFF" or flashes the "t" symbol and the time remaining until the next load is switched on/off.

 open circuit — breakage of the sensor circuit

 short circuit — short circuit of the sensor circuit

*Possible cause:* damage to the sensor and its chain, incorrect sensor type selected in the thermostat settings, the temperature measured by an analog sensor has gone beyond the range (see Tech. data table).

*Required action:* check the integrity of the sensor and the absence of mechanical damage to its chain, check for nearby power wires. Check the correctness of the colors during the connection of the digital sensor. Make sure the appropriate type is selected in the sensor settings.

**Emergency Timer Mode** This mode ensures the operation of the load in case of detector damage: in a 30-minute cyclic interval, the load is switched on for the set time, and the load is switched off for the rest of the time. The load operation time can be set in the range from 1 to 29 minutes using the "+" or "-" buttons. The screen will then display "t" and the time remaining until the next on/off. From the factory, the Mode value is "oFF", the load is permanently off. To make the load run continuously, increase the time to a maximum of "on", or to turn it off completely to a minimum of "oFF".

## ADDITIONAL INFORMATION

Please do not burn or dispose of the thermostat with household waste.

After the end of its service life, the product should be disposed of in accordance with applicable law.

The product is transported in packaging that ensures its preservation.

The thermostat can be transported by any kind of transportation (such as by car, plane, train or ship).

The date of manufacture is indicated on the device body. The shelf life is unlimited. Does not contain any harmful substances.

## SAFETY INSTRUCTIONS

To avoid injury and damage to the thermostat, carefully read and understand these instructions for yourself.

The installation of the thermostat should be carried out by a qualified electrician.

Do not connect 230 V mains voltage instead of the sensor (this will damage the thermostat).

Before starting the installation (disassembly) and connection (disconnection) of the thermostat, disconnect the power supply and follow the "Rules of an arrangement of Electric Installations".

Do not immerse the sensor with its connecting wire in liquid environment.

Do not connect the thermostat to the power supply in a disassembled state.

Prevent liquid or moisture from coming into contact with the thermostat.

Do not expose the device to extreme temperatures (above 40 °C or below -5 °C) and high humidity.

Do not clean the thermostat using chemicals such as benzene and solvents.

Do not store or use the thermostat in dusty environments.

Do not attempt to disassemble or repair the thermostat yourself.

Do not exceed the maximum current and power limits.

Use surge protectors to protect against overvoltage caused by lightning discharges.

Keep children away from playing with a functioning device as it is dangerous.

version: n8231\_2411

EMC Directive 2014/30/EU

Low Voltage Directive 2014/35/EU



04136, Ukraine, Kyiv region, Kyiv, 1-3 Pivnichno-Syretska str.  
Sales Department: +38 (091) 481-91-81, support@dse.com.ua  
www.ds-electronics.com company terneo.com